

# Double Door System

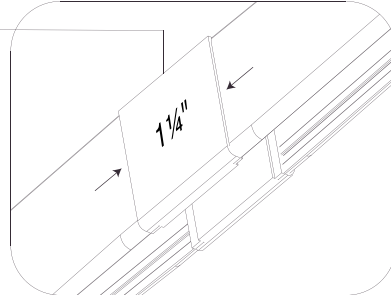

Insert the Upper Track Joiner between the Upper Tracks.

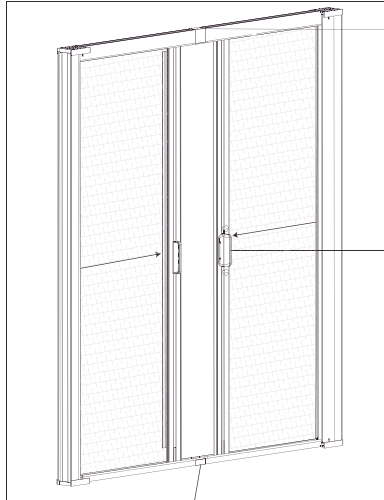
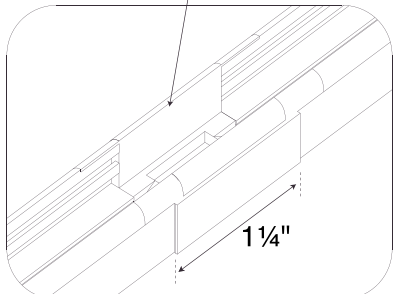

Insert the Lower Track Joiner between the Lower Tracks.

Only one Front Bar must use Locking Mechanism. Use rubber band to keep both Locking Knobs pushed towards each other.

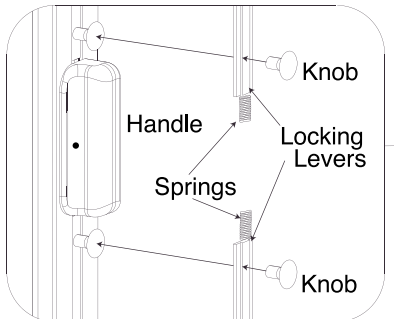

Once Handle is in correct position, mount screw.

Break tab on one side of both Front Bar End Caps for clearance.

Clean edge with a knife.

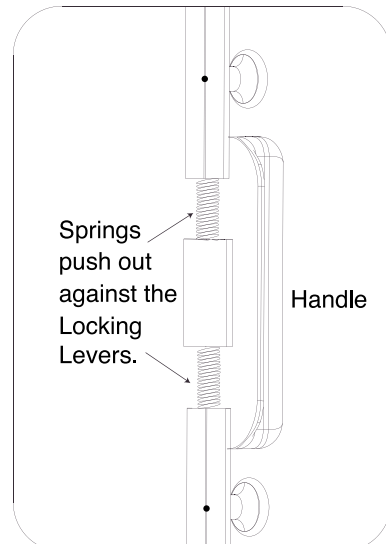
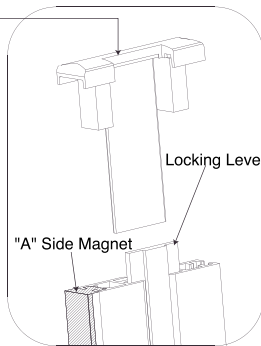

Do not put screws in Upper & Lower Track on door with Locking Mechanism.

## Assembly of the Locking Mechanism

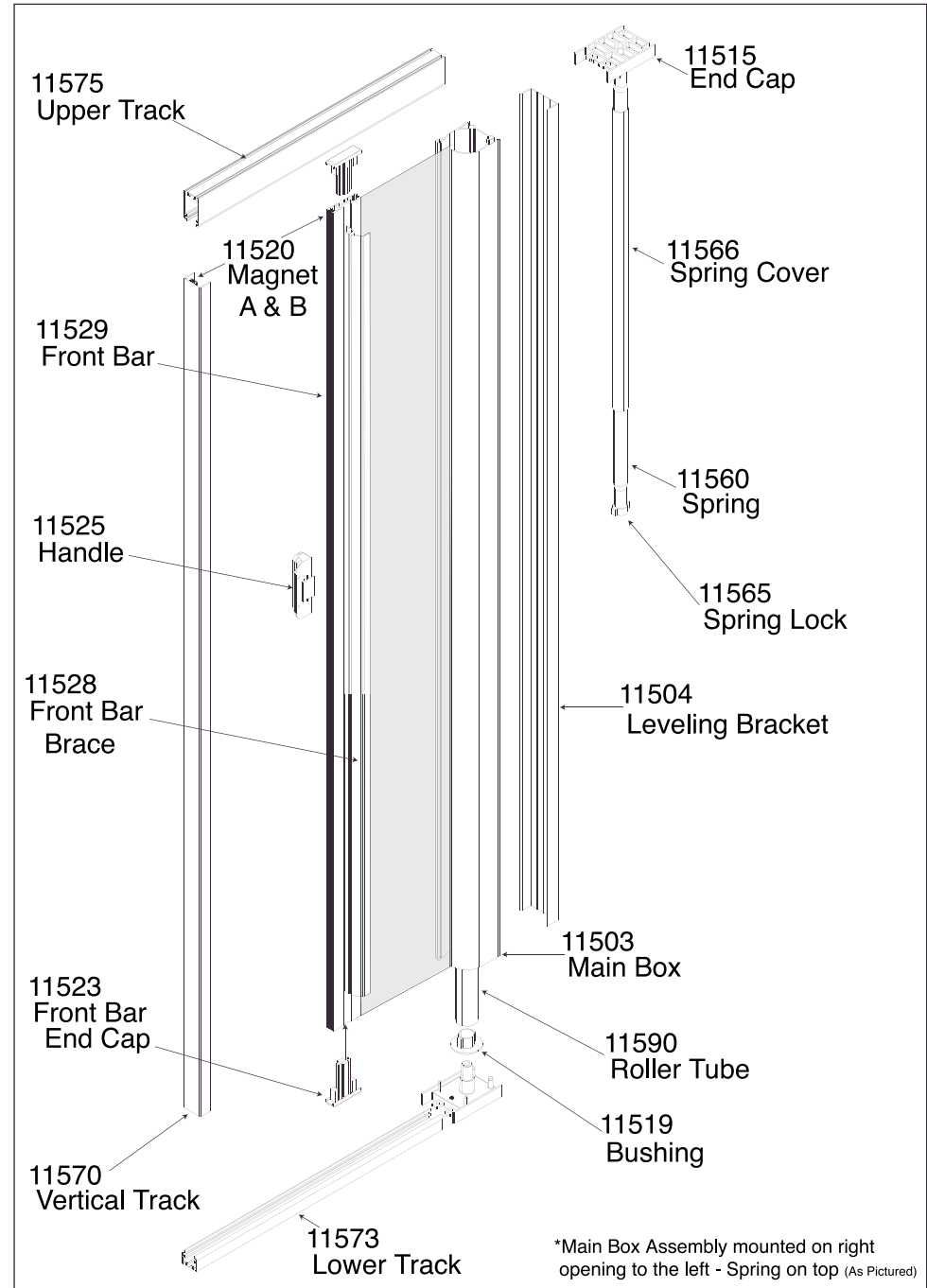

### 1. Measure the Door Opening

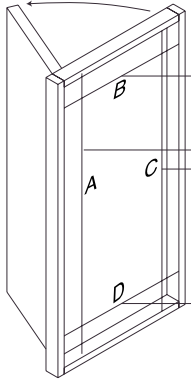

Opening		Subtractions		Cut Length
A=	-	*3/4"	=	
B=	-	*2-3/8"	=	
C=	-	0	=	
D=	-	*2-3/8"	=	

Cut Main Box Assembly to length 'A' minus \*3/4"-7/8".  
 Cut Leveling Bracket to length 'A' (no subtraction).  
 Cut Vertical Track to length 'C' (no subtraction).  
 Cut Lower Track to length 'D' minus \*2-3/8" - 2-1/2".  
 Cut Upper Track to length 'B' minus \*2-3/8" - 2-1/2".  
 Cut Front Bar Brace additional 3" from Main Box final length.

### 2. Prepare the Main Box Assembly

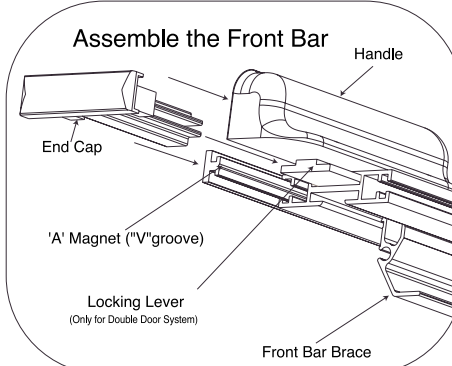
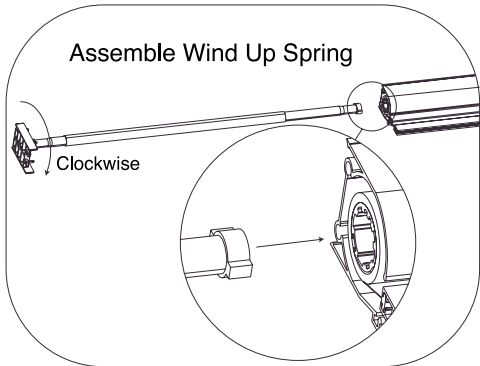
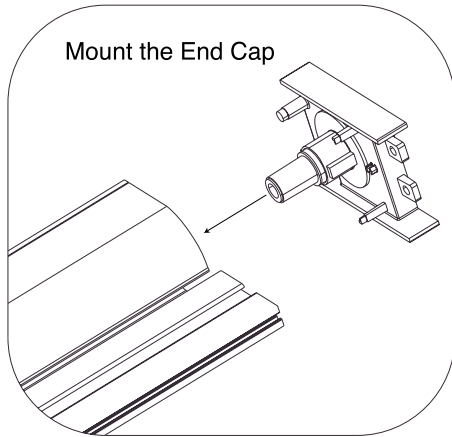
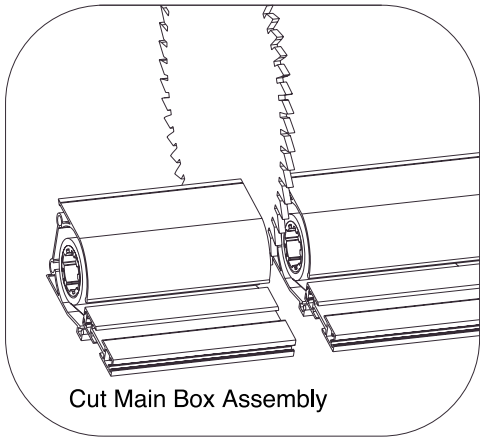

Width 3-4½ feet      Wind Up Spring 14-20 Turns  
 \*Door mounted on right opening to the left - Spring on Top  
 Door mounted on left opening to the right - Spring on Bottom

### 3. Mount the Leveling Bracket



Mount the Leveling Bracket using the supplied hardware.

Position Main Box onto Leveling Bracket. Do not attach. Before mounting Main Box Assembly finish steps 6 & 7.

### 4. Position the Main Box Assembly onto Leveling Bracket

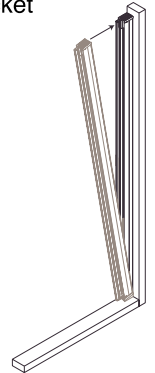

### 5. Mount the Vertical Track

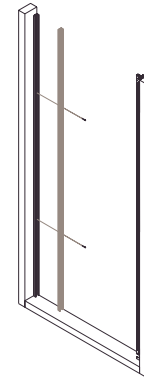

Slide 'B' Side Magnet into channel before mounting.

Mount the Vertical Track using supplied hardware.

Mount screws along the wide channel of the Vertical Track.

### 6. Mount the Lower Track



Mount the Tracks using the supplied hardware.

Slide the Upper and Lower Track onto the correct tab\* on the End Cap.

\*Right or Left depending on installation.

Mount the Main Box Assembly by putting a screw through available hole in the End Cap tabs. Additional fastening of Main Box Assembly and Leveling Bracket using your own hardware can be done with rivets or screws.

### 7. Mount the Upper Track

